

# **HCP PUMP**

<b>Model</b>	<b>80SFU22.2</b>
<b>Series</b>	<b>SF</b>
<b>Frequency</b>	<b>50</b>
<b>Phase / Volt</b>	<b>1 Ø / 230 V</b>
<b>Rated Current</b>	<b>14.6 A</b>
<b>Discharge</b>	<b>80 mm (3")</b>



## **Motor Data**

Input Power—P1	3 kW
Rated Power—P2	2.2 kW
Insulation Class	F
Max. Starts Per Hour	10
Rated Speed (rpm)	2840
Start Method	CAPACITOR
Ingress Protection Code	IP68
Explosion-Proof	NO

## **Technology**

Impeller Type	Vortex
Mechanical Seal	Double
Lubricating Oil VG32	850 CC
Solid Passage	50 mm (2")
Cooling Type	External cooling

## **Material**

Motor Frame	SUS316 (AISI 316)
Shaft	SUS316 (X5CrNiMo17-12-2)
Casing	SCS14 (G-X6CrNiMo1810)
Impeller	SCS14 (G-X6CrNiMo1810)
Mechanical Seal	CA/CE&SiC/SiC
Cable	VCT,H07RN-F
Upper and Lower Bearing	6204ZZ,6305ZZ

## **Liquid**

Maximum Ambient Temperature	0~40°C (32~104°F)
Maximum Installation Depth	20m (66ft)
Highest Liquid Temperature	40 °C (104°F)
Liquid Transported	Acid and alkali sewage

## **Others(Optional)**

Protection Device	Auto-cut Protector
Moisture Sensor	



# HCP PUMP

## PUMP PERFORMANCE CURVES

<b>Model</b>	80SFU22.2	<b>File NO.</b>	20230124154411
<b>Frequency</b>	50 Hz	<b>Ver NO.</b>	202003060911
<b>Discharge</b>	3" / 80 mm	<b>REFERENCE SPECIFICATION</b>	
<b>Output</b>	3 HP / 2.2 kW	<b>Output</b>	1.82 kW
<b>Std. Head</b>	13 m	<b>Efficiency</b>	46.2 %
<b>Std. Capacity</b>	0.4 m <sup>3</sup> /min		
<b>Phase / Volt</b>	1 Ø / 230 V		
<b>Rated Current</b>	14.6 A		
<b>Pole / rpm</b>	2 P / 2840 rpm		
<b>Start Method</b>	CAPACITOR		
<b>Insulation Class</b>	F		

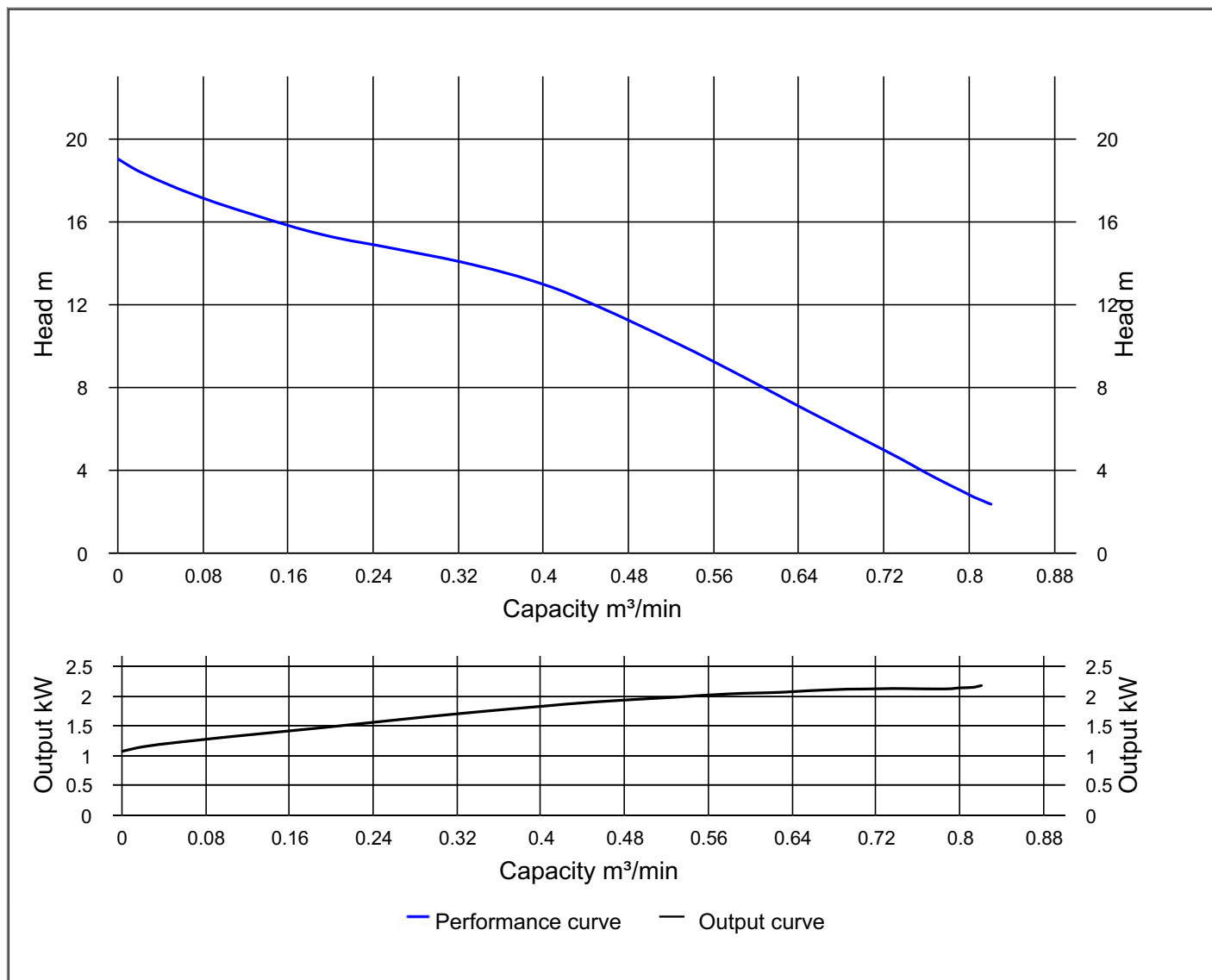

## DIMENSIONS

NO: S3SFU222030-00

MODEL: 80SFU21.5 / 22.2

50Hz 1Ø / 3Ø

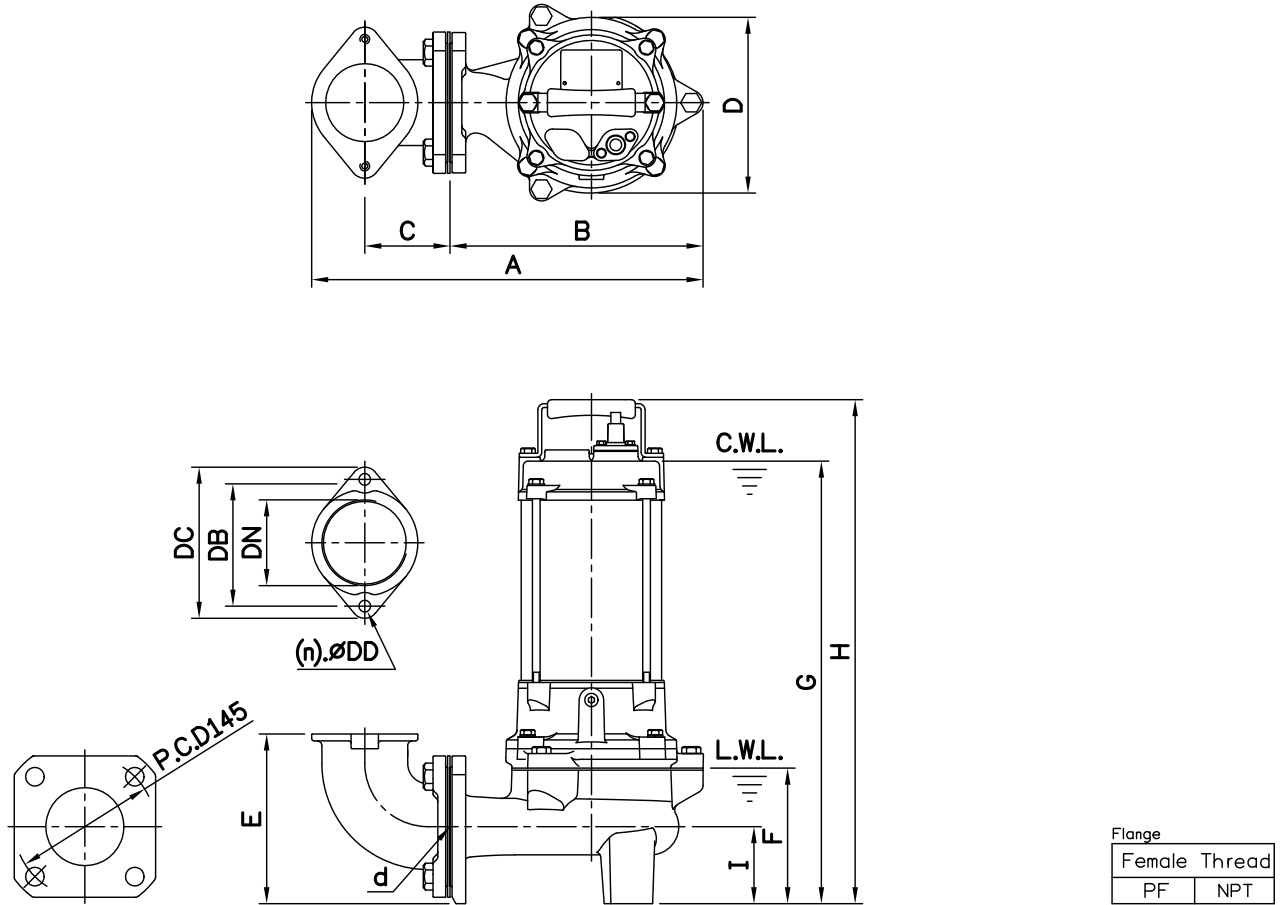

Dimensions—mm

Weight:kg

Model	d	A	B	C	D	E	F	G	H	I	WT1	Elbow (Flange)Set	DN	DB	DC	DD	(n)QTY	WT2
80SFU21.5 1Ø	80	402	260	88	202	174	139	523	586	79	31	ESB3-130K	80	130	155	12	2	4
80SFU21.5 3Ø	80	402	260	88	202	174	139	454	517	79	27	ESB3-130K	80	130	155	12	2	4
80SFU22.2 1Ø	80	402	260	88	202	174	139	535	598	79	34	ESB3-130K	80	130	155	12	2	4
80SFU22.2 3Ø	80	402	260	88	202	174	139	454	517	79	29	ESB3-130K	80	130	155	12	2	4

Dimensions—inch

Weight:lb

Model	d	A	B	C	D	E	F	G	H	I	WT1	Elbow (Flange)Set	DN	DB	DC	DD	(n)QTY	WT2
80SFU21.5 1Ø	3	15 <sup>3</sup> / <sub>16</sub>	10 <sup>1</sup> / <sub>4</sub>	3 <sup>3</sup> / <sub>16</sub>	7 <sup>15</sup> / <sub>16</sub>	6 <sup>7</sup> / <sub>8</sub>	5 <sup>1</sup> / <sub>2</sub>	20 <sup>9</sup> / <sub>16</sub>	23 <sup>1</sup> / <sub>16</sub>	3 <sup>1</sup> / <sub>8</sub>	68	ESB3-130K	3	5 <sup>1</sup> / <sub>8</sub>	6 <sup>1</sup> / <sub>8</sub>	1/2	2	9
80SFU21.5 3Ø	3	15 <sup>3</sup> / <sub>16</sub>	10 <sup>1</sup> / <sub>4</sub>	3 <sup>3</sup> / <sub>16</sub>	7 <sup>15</sup> / <sub>16</sub>	6 <sup>7</sup> / <sub>8</sub>	5 <sup>1</sup> / <sub>2</sub>	17 <sup>7</sup> / <sub>8</sub>	20 <sup>3</sup> / <sub>8</sub>	3 <sup>1</sup> / <sub>8</sub>	60	ESB3-130K	3	5 <sup>1</sup> / <sub>8</sub>	6 <sup>1</sup> / <sub>8</sub>	1/2	2	9
80SFU22.2 1Ø	3	15 <sup>3</sup> / <sub>16</sub>	10 <sup>1</sup> / <sub>4</sub>	3 <sup>3</sup> / <sub>16</sub>	7 <sup>15</sup> / <sub>16</sub>	6 <sup>7</sup> / <sub>8</sub>	5 <sup>1</sup> / <sub>2</sub>	21 <sup>1</sup> / <sub>16</sub>	23 <sup>3</sup> / <sub>16</sub>	3 <sup>1</sup> / <sub>8</sub>	75	ESB3-130K	3	5 <sup>1</sup> / <sub>8</sub>	6 <sup>1</sup> / <sub>8</sub>	1/2	2	9
80SFU22.2 3Ø	3	15 <sup>3</sup> / <sub>16</sub>	10 <sup>1</sup> / <sub>4</sub>	3 <sup>3</sup> / <sub>16</sub>	7 <sup>15</sup> / <sub>16</sub>	6 <sup>7</sup> / <sub>8</sub>	5 <sup>1</sup> / <sub>2</sub>	17 <sup>7</sup> / <sub>8</sub>	20 <sup>3</sup> / <sub>8</sub>	3 <sup>1</sup> / <sub>8</sub>	64	ESB3-130K	3	5 <sup>1</sup> / <sub>8</sub>	6 <sup>1</sup> / <sub>8</sub>	1/2	2	9

C.W.L.:Continuous Running Water Level  
L.W.L.:Lowest Running Water Level

WT1:Pump Weight(Without Cable)  
WT2:Elbow Set Weight

## DIMENSIONS

NO: T3SFU222030-00

MODEL: 80SFU21.5 / 22.2

50Hz 1Ø / 3Ø

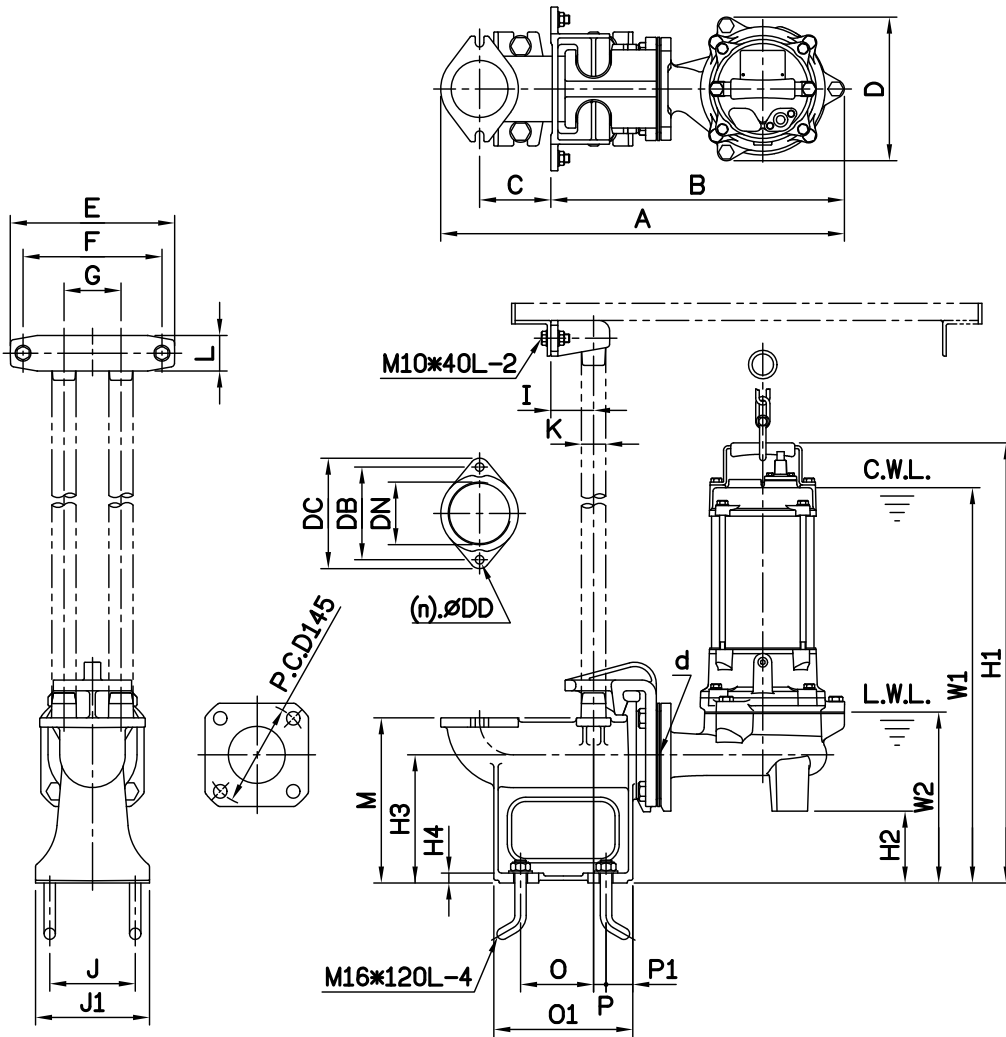

Flange	
Female Thread	
PF	NPT

Dimensions-mm

Elbow (Flange)Set	DN	DB	DC	DD	(n)QTY
ESF3-130	80	130	155	12	2

Dimensions-inch

Elbow (Flange)Set	DN	DB	DC	DD	(n)QTY
ESF3-130	3	5 1/8	6 1/8	1/2	2

Dimensions-mm

Model	d	A	B	C	D	E	F	G	I	J	J1	K	L	M	O	O1	P	P1	W1	W2	H1	H2	H3	H4	WT1	Weight:kg	
																										GRS Set	WT2
80SFU21.5 Ø1	80	567	412	100	202	230	195	80	60	120	160	1 1/4"	50	232	103	195	18	38	624	240	687	101	180	14	31	ST2-80	19
80SFU21.5 Ø3	80	567	412	100	202	230	195	80	60	120	160	1 1/4"	50	232	103	195	18	38	555	240	618	101	180	14	27	ST2-80	19
80SFU22.2 Ø1	80	567	412	100	202	230	195	80	60	120	160	1 1/4"	50	232	103	195	18	38	636	240	699	101	180	14	34	ST2-80	19
80SFU22.2 Ø3	80	567	412	100	202	230	195	80	60	120	160	1 1/4"	50	232	103	195	18	38	555	240	618	101	180	14	29	ST2-80	19

Dimensions-inch

Model	d	A	B	C	D	E	F	G	I	J	J1	K	L	M	O	O1	P	P1	W1	W2	H1	H2	H3	H4	WT1	Weight:lb	
																										GRS Set	WT2
80SFU21.5 Ø1	3	22 3/16	16 1/4	3 15/16	7 15/16	9 1/16	7 1/16	3 1/8	2 3/8	4 3/4	6 1/8	1 1/4	2	9 1/8	4 1/16	7 1/16	1 1/16	1 1/2	24 3/16	9 7/16	27 1/8	4	7 1/16	3/16	68	ST2-80	42
80SFU21.5 Ø3	3	22 3/16	16 1/4	3 15/16	7 15/16	9 1/16	7 1/16	3 1/8	2 3/8	4 3/4	6 1/8	1 1/4	2	9 1/8	4 1/16	7 1/16	1 1/16	1 1/2	21 1/8	9 7/16	24 5/16	4	7 1/16	3/16	60	ST2-80	42
80SFU22.2 Ø1	3	22 3/16	16 1/4	3 15/16	7 15/16	9 1/16	7 1/16	3 1/8	2 3/8	4 3/4	6 1/8	1 1/4	2	9 1/8	4 1/16	7 1/16	1 1/16	1 1/2	25 1/8	9 7/16	27 1/2	4	7 1/16	3/16	75	ST2-80	42
80SFU22.2 Ø3	3	22 3/16	16 1/4	3 15/16	7 15/16	9 1/16	7 1/16	3 1/8	2 3/8	4 3/4	6 1/8	1 1/4	2	9 1/8	4 1/16	7 1/16	1 1/16	1 1/2	21 1/8	9 7/16	24 3/16	4	7 1/16	3/16	64	ST2-80	42

C.W.L.:Continuous Running Water Level  
L.W.L.:Lowest Running Water Level

WT1:Pump Weight(Without Cable)  
WT2:GRS Set Weight

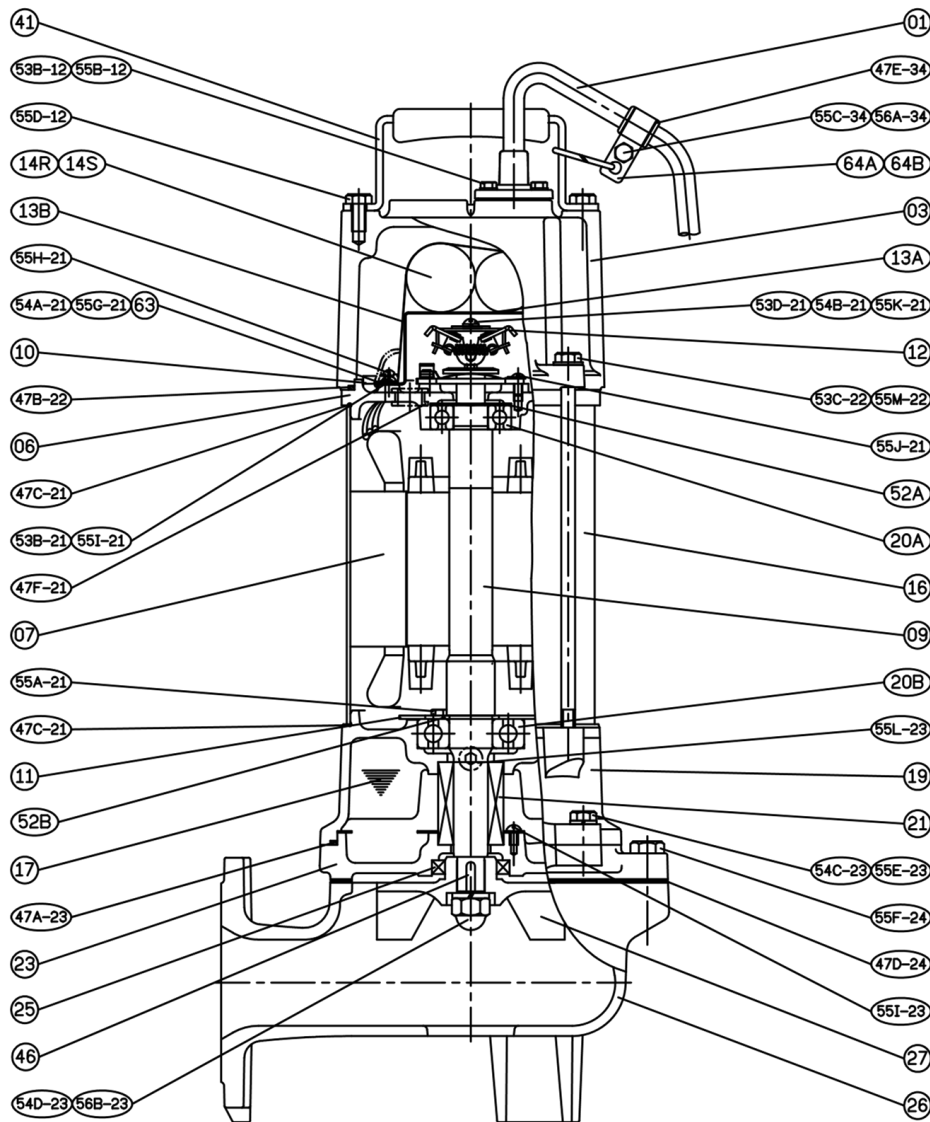

NO.	Part name	Material	QTY
01	Cable		1
03	Upper Cover	SCS14	1
06	Bracket	SCS14	1
07	Stator		1
09	Shaft End	SUS316	1
10	Auto-cut Protector		1
11	Bearing Fixer	SPCC	1
12	Centrifugal Switch		1
14R	Capacitor		1
14S	Start Capacitor		1
16	Motor Frame	SUS316	1
17	Lubricant		
19	Bearing Bracket	SCS14	1
20A	Bearing		1

NO.	Part name	Material	QTY
20B	Bearing		1
21	M. Seal	CA/CE & SiC/SiC	1
23	M. Seal Bracket	SCS14	1
25	Oil Seal	VITON	1
26	Casing	SCS14	1
27	Impeller	SCS14	1
41	Handle	SUS304	1
46	Impeller Key	SUS304	1
47	Gasket Kit		